



## Metrotile Shake



**Metrotile**<sup>®</sup>  
worldwide roofing systems

**Inspired by classic wooden roofs  
but with all the strength of steel.**

Metrotile Shake tiles have all the features of traditional wooden shakes, but without the problems of splitting, warping or increased fire risk. Enhanced shadow lines and visual contrasts are combined with lightweight, long-life steel.

Metrotile Shake tiles are stone-coated panels pressed from a high grade of Aluzinc<sup>®</sup> coated steel and are available in a wide selection of colours.

PRODUCT  
QUALITY  
**100%**  
GUARANTEED

Weatherproof  
guarantee  
of a  
lifetime



# Metrotile Shake

Lightweight high grade steel with Aluzinc® coating for incredible strength and resistance. Suitable for all roof shapes.

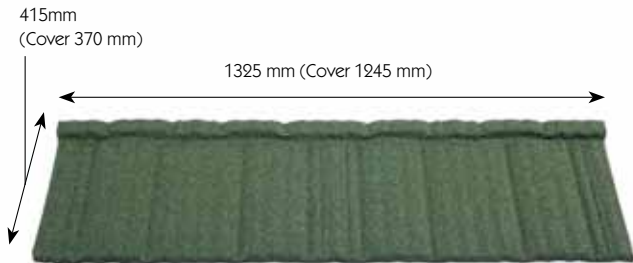

## Specifications

Minimum pitch	10°
Maximum pitch	90°
Size of tile - overall	1325 x 415 mm
Size of tile - cover	1245 x 370 mm
Gauge of steel	.450 mm
Linear cover width	1245 mm
Coverage	0.46 m <sup>2</sup> (2.17 tiles per m <sup>2</sup> )
Weight per m <sup>2</sup>	6.1 kg
Weight per tile	2.8 kg
Colours	The available standard colours are Charcoal, Terracotta, Red, Black, Greenstone, Coffee, Walnut, Tuscany, Brindle, Antique red, Antique grey, Rustic,... Also other colours available to order (ask your dealer for more information).

## Properties



### Lightweight

Light and easy to handle and install.



### Durable

Colour stability and protects against UV light.



### Stable

Resistance to extreme wind or earthquakes.



### Strong

Exceptional strength and resistant to damage.



### Fire proof

To be conform with the European standards

## Installation of the tiles

The Metrotile Shake tile panels can be interlocked either right over left or left over right with the side laps of one small corrugation.

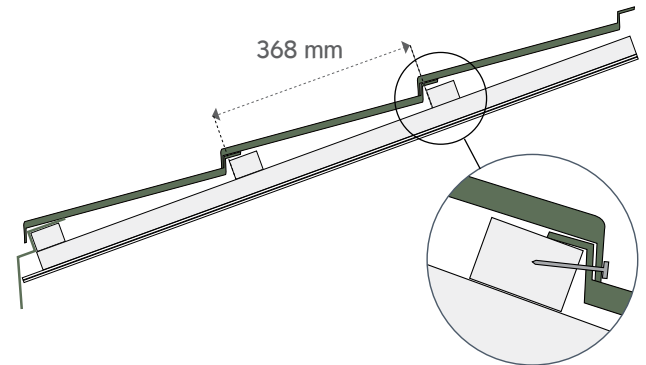

The panels are placed onto battens spacing 368 mm.

The downturned front edge and the upturned rear edge of each tile provides a strong, weatherproof, overlapping and interlocking roof covering. Each panel is secured by 4 nails in the front downturned edge into the side of the batten, positioned out of the water course.

Each panel or accessory can be cutted or bended in the shape of the roof. It is important to use tools recommended by Metrotile.

## Accessories

Metrotile offers a broad choice of accessories that fully integrate with the Metrotile Shake profile.

### • Ridges, junctions and end caps.

For use on ridges and hips in angle, square, rounded shape.

### • Barges, flashings and finishings.

For roof covering at foot, gables, verges, barges, against walls.

### • Other accessories.

Like ventilation systems, roof windows, light tubes, integrated solar panels, clear tiles,...

### • Installation equipment.

Everything you need for installation: nails, benders, guillotines,...

For a complete and detailed list of accessories and more information regarding the installation of a Metrotile roof, contact your dealer.