



Metrotile Bond



Metrotile[®]
worldwide roofing systems

A traditional and attractive roof with timeless effect.

The **Metrotile Bond** profile is designed to get the same appearance of the traditional clay roof style, with the additional benefits of steel roofing. Because of the downturned front and the upturned rear edges, the panels have a strong overlapping and interlocking tile covering, which provides an excellent durability, protection and resistance to wind lift or other extreme weather conditions.

Metrotile Bond is an eight tile, stone-coated panel pressed from a high grade of Aluzinc[®] coated steel and is available in a wide selection of colours to enhance any exterior colour scheme.

PRODUCT
QUALITY
100%
GUARANTEED

Weatherproof
guarantee
of a
lifetime



Metrotile Bond

Lightweight high grade steel with Aluzinc® coating for incredible strength and resistance. Suitable for all roof shapes.



Specifications

Minimum pitch	10°
Maximum pitch	90°
Size of tile - overall	1330 x 415 mm
Size of tile - cover	1270 x 370 mm
Gauge of steel	.450 mm
Linear cover width	1270 mm
Coverage	0.47 m ² (2.13 tiles per m ²)
Weight per m ²	6.2 kg
Weight per tile	2.8 kg
Colours	The available standard colours are Charcoal, Terracotta, Red, Black, Greenstone, Coffee, Walnut, Tuscany, Brindle, Antique red, Antique grey, Rustic,... Also other colours available to order (ask your dealer for more information).

Properties



Lightweight

Light and easy to handle and install.



Durable

Colour stability and protects against UV light.



Stable

Resistance to extreme wind or earthquakes.



Strong

Exceptional strength and resistant to damage.



Fire proof

To be conform with the European standards

Installation of the tiles

The Metrotile eight tile panels can be interlocked either right over left or left over right with the side laps of one small corrugation.

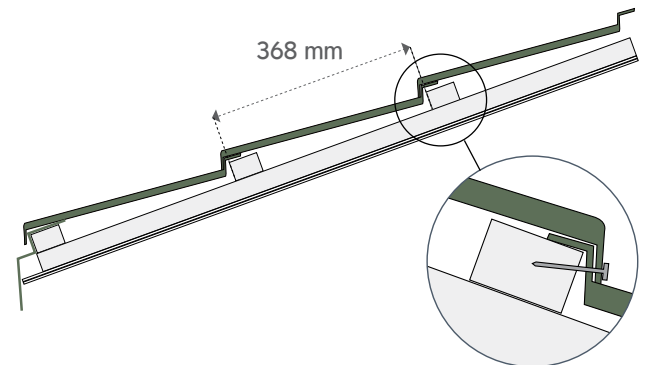

The panels are placed onto battens spacing 368 mm.

The downturned front edge and the upturned rear edge of each tile provides a strong, weatherproof, overlapping and interlocking roof covering. Each panel is secured by 4 nails in the front downturned edge into the side of the batten, positioned out of the water course.

Each panel or accessory can be cut or bent in the shape of the roof. It is important to use tools recommended by Metrotile.

Accessories

Metrotile offers a broad choice of accessories that fully integrate with the Metrotile Bond profile.

- **Ridges, junctions and end caps.**
For use on ridges and hips in angle, square, rounded shape.
- **Barges, flashings and finishings.**
For roof covering at foot, gables, verges, barges, against walls.
- **Other accessories.**
Like ventilation systems, roof windows, light tubes, integrated solar panels, clear tiles,...
- **Installation equipment.**
Everything you need for installation: nails, benders, guillotines,...

For a complete and detailed list of accessories and more information regarding the installation of a Metrotile roof, contact your dealer.